



In-Home Display Unit Product Application Guide

10 December 2018



An appropriate citation for this paper is:

Essential Services Commission 2018, In-Home Display Unit Product Application Guide: 10 December

Copyright notice

© Essential Services Commission, 2018



This work, In-Home Display Unit Product Application Guide, is licensed under a Creative Commons Attribution 4.0 licence [creativecommons.org/licenses/by/4.0]. You are free to re-use the work under that licence, on the condition that you credit the Essential Services Commission as author, indicate if changes were made and comply with the other licence terms.

The licence does not apply to any brand logo, images or photographs within the publication.

Contents

Introduction	1
About this guide	1
What are in-home display (IHD) units?	1
Who should use this guide	2
Seeking assistance	2
Legal context for this guide	2
1. Product performance and documentation requirements	3
2. Product approval process	6
2.1. Submitting an IHD unit product application	6
2.2. Laboratory test methodology approval	1
2.3. Proposed modifications to testing procedure	1
2.4. Laboratory test methodology	1
2.5. Laboratory test report and attachments	3
2.6. DNSP compatibility check for ZigBee IHD units	3
3. Commission laboratory test for ZigBee certified IHD units	5
3.1. Laboratory sample and documentation	5
3.2. Review of specifications	5
3.3. Test set-up	6
3.4. Testing	7
4. Commission laboratory test for non-ZigBee IHD units	12
4.1. Laboratory sample and documentation	12
4.2. Review of specifications	12
4.3. Test set-up	13
4.4. Testing	14
Glossary	19
Appendix A: Laboratory test report template	21
Appendix B: Laboratory test results – IHD screen shots	28
Appendix C: Laboratory test results – Data sets and plots	30

Introduction

This guide provides product applicants with guidance on how to apply for in-home display (IHD) units to be registered on our Register of Products, so that they are eligible to be installed and create Victorian energy efficiency certificates (VEECs) under the Victorian Energy Upgrades (VEU) program.

About this guide

This guide provides instructions on how to apply for an IHD unit (product category 30) to be listed on our Register of Products.

This guide is divided into the following sections:

- Section 1 outlines the performance criteria and documentary evidence required for IHD units.
- Section 2 provides an outline of the product approval process for IHD units
- Section 3 details the method to be used to test Zigbee IHD units
- Section 4 details the method to be used to test non-Zigbee IHD units

This guide must be read in conjunction with our Application Guide for Product Applicants which provides product applicants with information on:

- our Register of Products
- our product application and assessment process, including things to bear in mind throughout the process
- some product application functionality.

What are in-home display (IHD) units?

IHD units are designed to encourage energy efficient behaviour in residential consumers by providing near real-time feedback on household electrical energy consumption and indicative usage cost.

IHD units can be divided into two main types, ZigBee certified (also referred to as ZigBee enabled) and non-ZigBee IHD units.

ZigBee IHD units

These units communicate wirelessly over short ranges with ZigBee enabled Advanced Metering Infrastructure (AMI) meters, also known as smart meters, via an encrypted radio frequency. Installation of ZigBee devices require the IHD unit to be 'bound' to the smart meter. Once successfully bound, ZigBee IHD units can display or relay to a display residential energy consumption data that is accurate to the smart meter.

Non-ZigBee IHD units

These units can be used in conjunction with a wide range of metering types, including smart meters. Non-ZigBee IHD units generally require a sensor and transmitter to be installed on a residence's electricity meter or main electricity cable. This enables household energy consumption to be measured and transmitted to the IHD unit display via short-range radio signals. Non-ZigBee IHD units that require a sensor to be clamped on to the residence's main electricity cable must be installed by a qualified electrician.

Who should use this guide

You should use this guide if you are:

- applying for an IHD unit to be listed on our Register of Products under the Victorian Energy Upgrades (VEU) program.
- interested in understanding the product application requirements for IHD units under the VEU program.

You need a VEU account to apply for a product listing under the program. Create a VEU account at www.veu-registry.vic.gov.au/new-account

Seeking assistance

If you encounter difficulties with your application that cannot be resolved using this guide, contact us on (03) 9032 1310 or veu@esc.vic.gov.au

If you have submitted a product application, please use the designated 'notes' field in the online product assessment tool to communicate directly with the product officer responsible for assessing your application.

Legal context for this guide

We have prepared this guide as a general summary of relevant parts of:

- Victorian Energy Efficiency Target Act 2007 (the VEET Act)
- Victorian Energy Efficiency Target Regulations 2018 (the VEET Regulations)
- Victorian Energy Upgrades Specifications 2018 (the VEU specifications)
- Victorian Energy Efficiency Target Guidelines (the VEET guidelines)

View these documents at www.esc.vic.gov.au/veu-legislation

This guide should not be relied upon as substitute for legal advice and should be read in conjunction with the above source documents. In the event of inconsistency between this guide and the source documents, the content in the source documents apply.

1. Product performance and documentation requirements

This section details the program’s minimum product performance requirements, eligibility criteria and the evidentiary requirements to have an IHD unit listed on the Register of Products.

You will be required to submit an independent third party verification of the product performance against established safety and performance standards, such as a test report from an accredited laboratory.

It is recommended that you compare your device to the criteria outlined below to determine whether the IHD unit is suitable before undertaking laboratory testing. The capacity of a product to perform to specified standards is a requirement of listing on the Register of Products and the valid creation of VEECs. We do not accept deviations from the listed standards. If you are unable to provide sufficient evidence that a product is capable of meeting the minimum criteria, the product will not be approved.

Product category number	Product category	Product criteria	Documentary evidence
30A	ZigBee certified IHD unit	Complies with the ZigBee smart energy profile specification published on 1 Dec 2008 and the ZigBee smart energy profile specification version 1.1 published 23 Mar 2011.	ZigBee smart energy profile specification version 1.1 certification.
		<p>An IHD unit that:</p> <ul style="list-style-type: none"> • when installed in relation to an AMI, provides information directly to the consumer on the total electricity consumption of the residential premises • determines electricity consumption information from the sensing apparatus every 30 seconds or less • is able to store electricity energy consumption information from the previous 45 days • is able to display information to the consumer, in a numerical format and non-numerical format, that allows the consumer to easily distinguish between low and high consumption including: <ul style="list-style-type: none"> – electricity energy consumption information from the previous 45 days in intervals of each hour and each 	Test report with relevant attachments by a NATA accredited laboratory or equivalent body demonstrating compliance with the product criteria.

		<p>day</p> <ul style="list-style-type: none"> – the average total household electrical power consumption (W) for the displayed period, updated every 30 seconds or less – the total household electricity energy consumption (kWh) for the displayed period and the cost of that consumption, updated every 30 seconds or less • is able to display the tariff (cost per unit of energy consumed) and the total cost of electricity consumed for the period displayed <p>is able to permanently erase all consumption and tariff information held by the IHD unit.</p>	
		<ul style="list-style-type: none"> • A unit that is compatible with each distribution network service provider (DNSP) where the IHD is installed. 	DNSP test report.
Power source			
		<ul style="list-style-type: none"> • If any component is battery powered, that component uses a battery with a manufacturer's rated lifetime of at least 5 years or 	Manufacturer's declaration.
		<ul style="list-style-type: none"> • If mains powered, has an average electricity power consumption of 0.6 watts or less 	Test report (see above).
		<ul style="list-style-type: none"> • If mains powered, external power supply (if any) is MEPS registered. 	GEMS registration screen shot (www.energyrating.gov.au).
30B	Non-ZigBee certified IHD unit	<p>An IHD unit that:</p> <ul style="list-style-type: none"> • when installed in relation to any sensing apparatus, provides information directly to the consumer on the total electricity consumption of the residential premises • determines electricity consumption information from the sensing apparatus every 30 seconds or less • is able to store electricity energy consumption information from the previous 45 days • is able to display information to the consumer, in a numerical format and non-numerical format, that allows the consumer to easily distinguish between 	Test report with relevant attachments by a NATA accredited laboratory or equivalent body demonstrating compliance with the product criteria.

		<p>low and high consumption including:</p> <ul style="list-style-type: none"> – the electricity energy consumption information from the previous 45 days in intervals of each hour and each day – the average total household electrical power consumption (W) for the displayed period, updated every 30 seconds or less – the total household electricity energy consumption (kWh) for the displayed period and the cost of that consumption, updated every 30 seconds or less • is able to display the tariff (cost per unit of energy consumed) and the total cost of electricity consumed for the period displayed • is able to permanently erase all consumption and tariff information held by the IHD unit • provides electricity energy consumption information that is accurate to within 5% of actual consumption. 	
		<ul style="list-style-type: none"> • A unit that uses for its communications with the sensing apparatus and any display device, an encrypted communication protocol approved by us. 	<p>Manufacturer's description and declaration</p>
Power source			
		<ul style="list-style-type: none"> • If any component is battery powered, that component uses a battery with a manufacturer's rated lifetime of at least 5 years 	<p>Manufacturer's declaration.</p>
		<ul style="list-style-type: none"> • If mains powered, has an average electricity power consumption of 0.6 watts or less 	<p>Test report (see above).</p>
		<ul style="list-style-type: none"> • If mains powered, external power supply (if any) is MEPS registered. 	<p>GEMS registration screen shot (www.energyrating.gov.au).</p>

2. Product approval process

2.1. Submitting an IHD unit product application

The product approval process for IHD units is presented as a flow chart below.

Figure 1: VEET scheme product approval process for IHD unit

1. Laboratory test approval

- Applicant advises us whether the laboratory test will be undertaken in accordance with this guide.
- If an alternative methodology is proposed, the applicant must provide details to us for approval **before proceeding**

2. Laboratory test

Applicant has IHD unit laboratory tested for the minimum specifications outlined in the VEET Regulations

3. DNSP test

Only if the ZigBee IHD unit passes all conditions of the lab test, the applicant tests the IHD unit for compatibility with each distribution network service provider (DNSP) where the activity will be undertaken
Note: The IHD unit must be tested with at least one DNSP to be eligible for approval

4. Submit application

Applicant submits an online application for product approval to us via the VEU Registry at www.veu-registry.vic.gov.au, attaching:-

- laboratory test report and attachments
- DNSP test report (ZigBee IHD units only)

We assess the application and if satisfied that the IHD unit meets the VEET Regulations, the product and its specifications will be listed on the Register of Products.

2.2. Laboratory test methodology approval

We will only accept results from tests undertaken on an IHD unit with the same brand, model and firmware version as the IHD unit listed on the online application for product approval.

We will not accept test results from prototype or demonstration models and any mains powered IHD unit that does not have electrical safety certification from Energy Safe Victoria or an equivalent electrical safety authority.

You should inform us whether the laboratory test will be undertaken in accordance with this guide or whether an alternative methodology is proposed.

It is a requirement that all tests are discussed with us before testing is undertaken to ensure the test methodology is suitable for the IHD unit in question.

If an alternative methodology is proposed, you should submit the following documentation to us for approval:

- proposed test methodology outline
- proposed test configuration diagram

2.3. Proposed modifications to testing procedure

IHD units come in many different designs and operating regimes, and can be installed in relation to a range of electricity meters. The testing and approval of IHD units for energy efficiency programs is a new discipline and formulating a robust and repeatable test methodology suited to all possible IHD designs and operating environments is challenging.

We welcome suggestions from laboratories, IHD suppliers or other parties on how this testing might be improved. We reserve the right to modify test procedures at any time.

2.4. Laboratory test methodology

Once the IHD laboratory test methodology has been approved by us, you can proceed to laboratory test the IHD unit for the minimum specifications as outlined in the VEET Regulations.

2.4.1. Requirements for laboratory testing

The laboratory test for IHD units must meet the following accreditation requirements, standards and conditions.

Testing laboratory

The laboratory test must be undertaken by a third party, independent to the IHD manufacturer, supplier and VEU proponent.

Tests may only be undertaken by independent test laboratories that are NATA accredited to ISO/IEC 17025 for testing in areas such as electronic equipment, energy efficiency of appliances, power or similar. However, it is preferable that the facility be NATA accredited to AS/NZS 62301-2005 - Household electrical appliances – measurement of standby power.

General conditions

The general conditions for all tests, including the test room, power supply, voltage waveform, power measurement accuracy, and the selection and preparation of appliances and equipment, must be performed in accordance with AS/NZS 62301-2005 - Household electrical appliances – measurement of standby power.

Testing equipment

The power meters used in the laboratory tests must meet the accuracy requirements of AS/NZS 62301 Clause 4.4, 2% or better.

Sample IHDs

Samples of each IHD unit model, selected at random by an independent party must be tested. We will not accept test results from prototype or demonstration models.

We will only accept results from laboratory tests undertaken on an IHD unit with the same brand, model number and firmware version as the IHD unit applied for online.

Electrical authority approval

Where applicable, you must provide evidence that the IHD unit has received electrical authority approval or equivalent from a relevant authority (e.g. Energy Safe Victoria). We will not assess any applicable unit that does not have electrical authority approval or equivalent.

MEPS

For mains powered IHD units with an external power supply (commonly known as an 'AC adaptor', 'plug pack' or 'power pack'), the applicant should check whether the external power supply requires Minimum Energy Performance Standards (MEPS) registration and, if so, that it is registered for MEPS as specified in AS/NZS 4665 - External power supplies.

C-tick or RCM compliance label

You should supply evidence that the IHD unit has a C-tick or Regulatory Compliance Mark (RCM) compliance label for electromagnetic compatibility (EMC).

2.5. Laboratory test report and attachments

Once the laboratory has completed the laboratory test for ZigBee or non-ZigBee IHDs, the testing laboratory should complete the laboratory test report, as per the template provided in Appendix A, including the following:

- Cover sheet
- Checklist
- Testing details
- Relevant test summary report

The testing laboratory should attach the following to the laboratory test report:

- Relevant documentation as outlined in the test report checklist in Appendix A
- IHD screen shots (or photographs) as outlined in Appendix B
- Time series data sets and data plots as outlined in Appendix C

2.6. DNSP compatibility check for ZigBee IHD units

To be eligible under the VEU program, ZigBee IHD units only must be tested for compatibility with each distribution network service provider (DNSP) where the activity will be undertaken. ZigBee IHD units must be tested with at least one DNSP to be eligible for approval.

Applicants should only proceed to test the ZigBee IHD unit for compatibility with DNSPs if the IHD unit has been laboratory tested and passed all conditions of our laboratory test for ZigBee certified IHDs, outlined in Section 3 of this guide.

You should contact the relevant DNSP where the ZigBee IHD will be installed and request that the device be tested for compatibility with the DNSP.

In Victoria, there are currently five DNSPs in operation:

- CitiPower
- Jemena
- Powercor
- SP Ausnet
- United Energy

To have the IHD tested, you will need to provide the DNSP with the following:

- Four sample IHDs (to be retained by the DNSP for future testing)
- Unique IHD installation codes
- IHD ZigBee certification
- IHD technical specifications including firmware version
- IHD user manual

You should request a test report from the DNSP that contains the following information:

- IHD brand
- IHD model
- IHD firmware version
- Test date
- DNSP declaration stating that the IHD is compatible with their network

3. Commission laboratory test for ZigBee certified IHD units

The following methodology should be used to laboratory test ZigBee IHD units for the minimum specifications outlined in the VEET Regulations.

3.1. Laboratory sample and documentation

You must provide the testing laboratory with:

- Sample ZigBee test-certified IHD unit with any sleep mode disabled
- Sample ZigBee production-certified IHD unit
- Sample IHD unit that has recorded 45 days historical energy consumption and cost data (only required if the IHD unit is not capable of pre-loading with historical data)
- Interface to download data from the IHD unit (e.g. USB, RS-232) and any associated software
- IHD unit serial number
- IHD unit media access control (MAC) address
- IHD unit installation code or trust centre / link key
- IHD unit technical specifications including firmware version and polling rate
- IHD unit user manual
- C-Tick or RCM compliance label for electromagnetic compatibility (EMC)
- ZigBee smart energy profile specification version 1.1 certification (backwards compatible with certified ZigBee smart energy products version 1.0)
- Certificate of electrical authority approval or equivalent where required
- MEPS registration if the IHD unit has an applicable external power supply

If **any** IHD component is **solely** battery powered:

- Sample battery / batteries used by the IHD unit
- Manufacturer's battery lifetime statement

3.2. Review of specifications

3.2.1. Review 1 - ZigBee certification

The laboratory should review the applicant's ZigBee certification documents and confirm that the IHD unit has been tested and certified by the ZigBee alliance as compliant with:

- ZigBee smart energy profile specification version 1.1.
- Backwards compatible with certified ZigBee smart energy products version 1.0.

3.2.2. Review 2 – battery lifetime (only for IHD components that are solely battery powered)

The laboratory should review the manufacturer’s battery lifetime statement(s) to determine the following:

- The battery’s rated lifetime is at least 5 years
- Manufacturer’s battery lifetime statement corresponds to the same brand and model of battery / batteries supplied with the IHD unit.

3.3. Test set-up

Set-up as outlined in Figure 2:

- If the IHD unit has battery back-up, ensure that it is fully charged before testing
- If mains powered, connect a power meter between the IHD unit (including any AC adaptor or charging dock) and the power point
- Activate the IHD display or if the IHD unit does not have a dedicated display, connect the device to a display
- Bind the IHD unit to the smart meter
- Input or download electricity tariff information into the IHD unit (cost per unit of energy consumed for time period of use)
- To simulate household energy consumption, connect a variable power load with an average residential power factor and standard AC input to the smart meter
- Enable time-stamped data logging as outlined in Table 2. Data should be logged at intervals equivalent to the polling rate of the IHD unit.

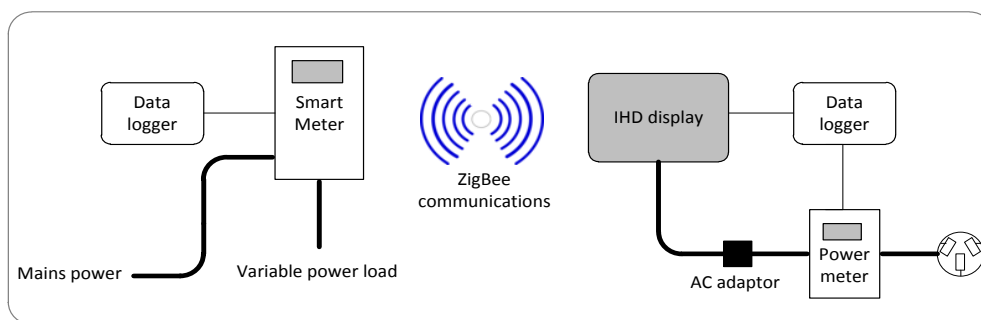

Figure 2: Example test configuration for ZigBee certified, mains powered IHD unit

Table 2: Data to be recorded during laboratory test for ZigBee IHD units

Record Data logger	Power consumption	Energy consumption	Cost of energy consumption	IHD power consumption
Smart meter	X	X		
IHD display	X	X	X	
Power meter				X

3.4. Testing

The testing laboratory may wish to combine tests for efficiency, however for the purposes of this document these tests are listed separately.

3.4.1. Test 1:Tariff display

- Procedure:**
- Determine whether the IHD unit is able to display the programmed tariffs (in cost per unit of energy consumed for each time of use period)
 - Record all methods available to consumers to enter tariff rates into the IHD unit
 - Record the number of tariffs the IHD unit is capable of displaying
 - Capture IHD unit display screen shot of the tariff display

3.4.2. Test 2:Polling frequency

- Duration:** 30 minutes
- Procedure:**
- Perform this test using the IHD unit sample with sleep functionality disabled
 - Allow the IHD unit to record energy consumption data for 30 minutes
 - Use a ZigBee packet sniffer to determine how often the IHD unit is polling the smart meter for energy consumption information.
- Data log:** Record how often the IHD unit is polling the smart meter for energy consumption information.
- Data analysis:**
- Determine how often the IHD unit is polling the smart meter for energy consumption information
 - Determine whether the IHD unit polls the smart meter for energy consumption information at least every 30 seconds.

3.4.3. Test 3: Power consumption display

Duration:	4 hours
Procedure:	<ul style="list-style-type: none">• Perform this test using the IHD unit sample with sleep functionality disabled• Allow the IHD unit to record electrical power consumption (in Watts) for 4 hours• during the test period, vary the power load once every 15 minutes.
Data log:	<ul style="list-style-type: none">• Smart meter: record electrical power consumption (in Watts)• IHD: record average electrical power consumption (in Watts)
Data analysis:	<p>Compare electrical power consumption data recorded from the smart meter to that recorded by the IHD unit to determine whether:</p> <ul style="list-style-type: none">• the IHD unit displays average electrical power consumption (in Watts) accurate to the smart meter and is updated at least every 30 seconds in a numerical format. Capture IHD unit display screen shot• the IHD unit displays average electrical power consumption (in Watts) accurate to the smart meter and is updated at least every 30 seconds in a non-numerical format that distinguishes high and low consumption. Capture IHD unit display screen shot.

3.4.4. Test 4: Energy consumption and cost display

Duration:	4 hours
Procedure:	<ul style="list-style-type: none">• Perform this test using the IHD unit sample with sleep functionality disabled• Allow the IHD unit to record electrical energy consumption (in kWh) for 4 hours• During the test period, vary the power load once every 15 minutes.
Data log:	<ul style="list-style-type: none">• Smart meter: record electrical energy consumption (in kWh)• IHD unit: record electrical energy consumption (in kWh) and the cost of that consumption
Data analysis:	<ul style="list-style-type: none">• Compare electrical energy consumption data recorded from the smart meter to that recorded by the IHD unit to determine whether:<ul style="list-style-type: none">– IHD unit displays total electrical energy consumption (in kWh) accurate to the smart meter and is updated at least every 30 seconds in a numerical format. Capture IHD unit display screen shot– IHD unit displays total electrical energy consumption (in kWh) accurate to

the smart meter and is updated at least every 30 seconds in a non-numerical format that distinguishes high and low consumption. Capture IHD unit display screen shot.

- Calculate the cost of total electricity consumption using the electricity tariff programmed into the IHD unit and the electrical energy consumption data recorded from the smart meter.
 - Compare this figure to the cost of total electrical energy consumption recorded by the IHD unit to determine whether:
 - IHD unit displays the cost of total electrical energy consumption for the displayed period accurate to the smart meter and is updated at least every 30 seconds in a numerical format. Capture IHD unit display screen shot
 - IHD unit displays the cost of total electrical energy consumption for the displayed period accurate to the smart meter and is updated at least every 30 seconds in a non-numerical format that distinguishes high and low consumption. Capture IHD unit display screen shot.

3.4.5. Test 5: Historical data storage and display

Option 1: To be used if the IHD unit is capable of pre-loading with historical data

Procedure: Pre-load the IHD unit with 45 days of simulated household electrical energy consumption and cost data.

Data analysis: Determine whether the IHD unit is able to store and display the 45 days of pre-loaded electrical energy consumption and cost data in the following formats:

- intervals no longer than one hour per day in a numerical format. Capture screen shot
- intervals no longer than one hour per day in a non-numerical format that distinguishes high and low consumption. Capture screen shot
- intervals no longer than one day per week in a numerical format. Capture screen shot
- intervals no longer than one day per week in a non-numerical format that distinguishes high and low consumption. Capture screen shot.

Option 2: To be used if the IHD unit is not capable of pre-loading with historical data

Procedure: Use the sample IHD unit that has recorded 45 days of electrical energy consumption and cost data.

Data analysis: Determine whether the IHD unit is able to store and display the 45 days of pre-

recorded electrical energy consumption and cost data in the following formats:

- intervals no longer than one hour per day in a numerical format. Capture screen shot.
- intervals no longer than one hour per day in a non-numerical format that distinguishes high and low consumption. Capture screen shot.
- intervals no longer than one day per week in a numerical format. Capture screen shot.
- intervals no longer than one day per week in a non-numerical format that distinguishes high and low consumption. Capture screen shot.

Option 3: To be used if the IHD unit is not capable of pre-loading with historical data and it is not possible to provide a sample IHD unit that has recorded 45 days electrical energy consumption data

Duration: 45 days

Procedure: Allow the IHD unit to record electrical energy consumption and the cost of that consumption for 45 days.

Data log: IHD unit: record electrical energy consumption and consumption cost data.

Data analysis: Determine whether the IHD unit is able to store and display the 45 days electrical energy consumption and cost data in the following formats:

- intervals no longer than one hour per day in a numerical format. Capture screen shot
- intervals no longer than one hour per day in a non-numerical format that distinguishes high and low consumption. Capture screen shot
- intervals no longer than one day per week in a numerical format. Capture screen shot
- intervals no longer than one day per week in a non-numerical format that distinguishes high and low consumption. Capture screen shot.

3.4.6. Test 6: IHD power consumption (for mains powered IHD units only)

Duration: 24 hours

Set-up: Perform this test using the sample IHD unit with sleep functionality enabled.

- Procedure:**
- Activate the IHD unit display for one minute
 - If IHD unit display has more than one screen (e.g. historical data, cost/kWh), activate each screen during the one minute test period
 - After one minute, discontinue IHD unit screen activation and allow the IHD unit to enter sleep or low power mode (if the IHD unit has this functionality)
 - Continue recording power consumption for the remainder of the 24 hour test

period (23 hours and 59 minutes).

Data log: Power meter: record the energy consumption of the IHD unit including any AC adaptor or charging dock.

Data analysis:

- At the end of the test period, divide the IHD unit's total 24 hour energy consumption by 24 (Watts = total watt-hours / hours) to determine the average power consumption of the IHD in Watts
- Determine whether the IHD unit's average power consumption is $\leq 0.6W$

3.4.7. Test 7: Erasable memory

Procedure:

- After completing all tests, erase all energy consumption, tariff and other data that was entered into the IHD unit from the memory using the device's consumer functions
- Ensure that data cannot be recalled after being erased
- Capture time-stamped IHD unit screen shots before and after erasing the memory.

4. Commission laboratory test for non-ZigBee IHD units

The following methodology should be used to laboratory test non-ZigBee IHD units for the minimum specifications outlined in the VEET Regulations.

4.1. Laboratory sample and documentation

The applicant must provide the testing laboratory with:

- sample IHD unit with any sleep mode disabled
- sample IHD unit with any sleep mode enabled
- sample IHD unit that has recorded 45 days historical energy consumption and cost data (only required if the IHD unit is not capable of pre-loading with historical data)
- interface to download data from the IHD unit (e.g. USB, RS-232) and any associated software
- IHD unit serial number
- IHD unit technical specifications including the firmware version and polling rate
- IHD unit user manual
- C-tick or RCM compliance label for electromagnetic compatibility (EMC)
- IHD unit communications protocol data encryption specifications
- manufacturer's declaration stating that the communication protocol between the IHD unit and the sensing apparatus is securely encrypted
- certificate of electrical authority approval or equivalent where required
- MEPS registration if the IHD unit has an applicable external power supply

If **any** IHD component is **solely** battery powered:

- sample battery / batteries used by the IHD unit
- manufacturer's battery lifetime statement

4.2. Review of specifications

4.2.1. Review 1: Data encryption

The laboratory should review:

- manufacturer's data encryption specifications for the IHD unit's communications protocol
- manufacturer's declaration that the communication protocol between the IHD unit and the sensing apparatus is securely encrypted

The laboratory should determine whether the communication protocol between the IHD unit and the sensing apparatus is securely encrypted.

4.2.2. Review 2: Battery lifetime (only for IHD unit components that are solely battery powered)

The laboratory should review the manufacturer's battery lifetime statement(s) to determine the following:

- the battery's rated lifetime is at least 5 years
- manufacturer's battery lifetime statement corresponds to the same brand and model of battery / batteries supplied with the IHD unit

4.3. Test set-up

Set-up as outlined in Figure 3:

- Connect an electricity meter to the main power supply
- If the IHD unit has battery back-up, ensure that it is fully charged before testing
- If mains powered, connect a power meter between the IHD unit (including any AC adaptor or charging dock) and the power point
- Connect IHD transmitter to the IHD sensor
- Connect the IHD sensor to the electricity meter or if the IHD sensor is a clamp-on device, connect it to the main power cable
- Activate the IHD display or if the IHD unit does not have a dedicated display, connect the device to a display
- Input or download electricity tariff information into the IHD unit (cost per unit of energy consumed for time period of use)
- To simulate household energy consumption, connect a variable, reactive power load with an average residential power factor and standard AC input to the electricity meter
- Enable time-stamped data logging as outlined in Table 3. Data should be logged at intervals equivalent to the polling rate of the IHD unit.

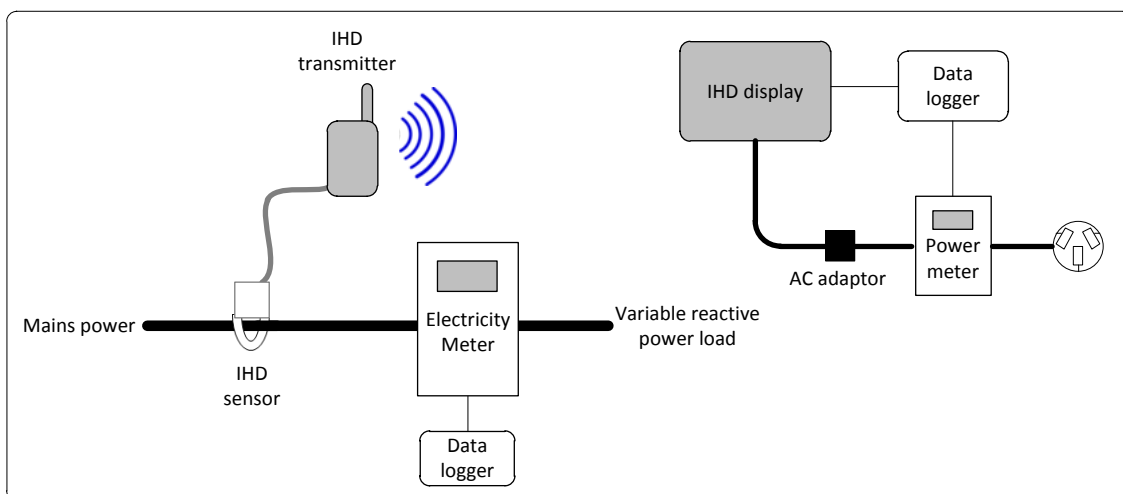

Figure 3: Example test configuration for non-ZigBee, mains powered IHD unit

Note: this test configuration is for single phase IHD units, three-phase IHD units will require two additional sensors

Table 3: Data to be recorded during laboratory test for non-ZigBee IHD units

Record data logger	Power consumption	Energy consumption	Cost of energy consumption	IHD power consumption
Electricity meter	X	X		
IHD unit display	X	X	X	
Power meter				X

4.4. Testing

The testing laboratory may wish to combine tests for efficiency, however for the purposes of this document these tests are listed separately.

4.4.1. Test 1: Tariff display

- Procedure:**
- Determine whether the IHD unit is able to display the programmed tariffs (in cost per unit of energy consumed for each time of use period)
 - Record all methods available to consumers to enter tariff rates into the IHD unit
 - Record the number of tariffs the IHD unit is capable of displaying
 - Capture IHD display screen shot of the tariff display

4.4.2. Test 2: Polling frequency

- Duration:** 30 minutes
- Procedure:**
- Perform this test using the IHD unit sample with sleep functionality disabled
 - Allow the IHD unit to record energy consumption data for 30 minutes
 - Vary the reactive power load at the same frequency as the IHD unit manufacturer's stated polling rate.
- Data log:**
- Electricity meter: record electrical power (in watts)
 - IHD unit: record electrical power (in watts)
- Data analysis:** Compare electrical power recorded by the electricity meter to that recorded by the IHD unit to determine:
- how often the IHD unit is polling for energy consumption information
 - whether the IHD unit polls for energy consumption information at least every 30 seconds.

4.4.3. Test 3: Power consumption display

Duration:	4 hours
Procedure:	<ul style="list-style-type: none">• Perform this test using the IHD unit sample with sleep functionality disabled• Allow the IHD unit to record electrical power consumption (in watts) for 4 hours• During the testing period, vary the reactive power load as follows:<ul style="list-style-type: none">– 10 A for 1 hour– 7.5 A for 1 hour– 5 A for 1 hour– 2.5 A for 1 hour
Data log:	<ul style="list-style-type: none">• Electricity meter: record electrical power consumption (in watts)• IHD unit: record average electrical power consumption (in watts)
Data analysis:	<p>Compare electrical power consumption data recorded from the electricity meter to that recorded by the IHD unit to determine whether:</p> <ul style="list-style-type: none">• IHD unit displays average electrical power consumption (in watts) in a numerical format, accurate to within 5% of actual power consumption and updated at least every 30 seconds. Capture IHD unit display screen shot• IHD unit displays average electrical power consumption (in watts) in a non-numerical format that distinguishes high and low consumption, accurate to within 5% of actual power consumption and updated at least every 30 seconds. Capture IHD unit display screen shot.

4.4.4. Test 4: Energy consumption and cost display

Duration:	4 hours
Procedure:	<ul style="list-style-type: none">• Perform this test using the IHD unit sample with sleep functionality disabled• Allow the IHD unit to record electrical energy consumption (in kWh) for 4 hours• During the testing period, vary the reactive power load as follows:<ul style="list-style-type: none">– 10 A for 1 hour– 7.5 A for 1 hour– 5 A for 1 hour– 2.5 A for 1 hour

- Data log:**
- Power meter: record electrical energy consumption (in kWh)
 - IHD unit: record electrical energy consumption (in kWh) and the cost of that consumption

- Data analysis:**
- Compare electrical energy consumption data recorded from the electricity meter to that recorded by the IHD unit to determine whether:
 - IHD unit displays total electrical energy consumption (in kWh) in a numerical format, accurate to within 5% of actual power consumption and updated at least every 30 seconds. Capture IHD unit display screen shot
 - IHD unit displays total electrical energy consumption (in kWh) in a non-numerical format that distinguishes high and low consumption, accurate to within 5% of actual power consumption and updated at least every 30 seconds. Capture IHD unit display screen shot.
 - Calculate the cost of total electricity consumption using the electricity tariff programmed into the IHD unit and the electrical energy consumption data recorded from the electricity meter
 - Compare this figure to the cost of total electrical energy consumption recorded by the IHD unit to determine whether:
 - IHD unit displays the cost of total electrical energy consumption in a numerical format, accurate to within 5% of actual energy consumption cost and updated at least every 30 seconds. Capture IHD unit display screen shot.
 - IHD unit displays the cost of total electrical energy consumption in a non-numerical format that distinguishes high and low consumption, accurate to within 5% of actual energy consumption cost and updated at least every 30 seconds Capture unit IHD display screen shot.

4.4.5. Test 5: Historical data storage and display

Option 1: To be used if the IHD unit is capable of pre-loading with historical data

Procedure: Pre-load the IHD unit with 45 days of simulated household electrical energy consumption and cost data.

Data analysis: Determine whether the IHD unit is able to store and display the 45 days of pre-loaded electrical energy consumption and cost data in the following formats:

- intervals no longer than one hour per day in a numerical format. Capture screen shot
- intervals no longer than one hour per day in a non-numerical format that distinguishes high and low consumption. Capture screen shot

- intervals no longer than one day per week in a numerical format. Capture screen shot
- intervals no longer than one day per week in a non-numerical format that distinguishes high and low consumption. Capture screen shot.

Option 2: To be used if the IHD unit is not capable of pre-loading with historical data

Procedure: Use the sample IHD unit that has recorded 45 days of electrical energy consumption and cost data.

Data analysis: Determine whether the IHD unit is able to store and display the 45 days of pre-recorded electrical energy consumption and cost data in the following formats:

- intervals no longer than one hour per day in a numerical format. Capture screen shot
- intervals no longer than one hour per day in a non-numerical format that distinguishes high and low consumption. Capture screen shot
- intervals no longer than one day per week in a numerical format. Capture screen shot
- intervals no longer than one day per week in a non-numerical format that distinguishes high and low consumption. Capture screen shot.

Option 3: To be used if the IHD unit is not capable of pre-loading with historical data and it is not possible to provide a sample IHD unit that has recorded 45 days electrical energy consumption data.

Duration: 45 days

Procedure: Allow the IHD unit to record electrical energy consumption and the cost of that consumption for 45 days.

Data log: IHD unit: record electrical energy consumption and consumption cost data

Data analysis: Determine whether the IHD unit is able to store and display the 45 days electrical energy consumption and cost data in the following formats:

- intervals no longer than one hour per day in a numerical format. Capture screen shot
- intervals no longer than one hour per day in a non-numerical format that distinguishes high and low consumption. Capture screen shot
- intervals no longer than one day per week in a numerical format. Capture screen shot
- intervals no longer than one day per week in a non-numerical format that

distinguishes high and low consumption. Capture screen shot.

4.4.6. Test 6: IHD power consumption (for mains powered IHD units only)

Duration: 24 hours

Set-up: Perform this test using the sample IHD unit with sleep functionality enabled.

Procedure:

- Activate the IHD unit display for one minute
- If IHD unit display has more than one screen (e.g. historical data, cost/kWh), activate each screen during the one minute test period
- After one minute discontinue IHD screen activation and allow the IHD unit to enter sleep or low power mode (if the IHD unit has this functionality)
- Continue recording power consumption for the remainder of the 24 hour test period (23 hours and 59 minutes).

Data log: Power meter: record the energy consumption of the IHD unit including any AC adaptor or charging dock

Data analysis:

- At the end of the test period, divide the IHD unit's total 24 hour energy consumption by 24 (watts = total watt-hours / hours) to determine the average power consumption of the IHD unit in watts
- Determine whether the IHDs' average power consumption is $\leq 0.6W$.

4.4.7. Test 7: Erasable memory

Procedure:

- After completing all tests, erase all energy consumption, tariff and other data that was entered into the IHD unit from the memory using the device's consumer functions
- Ensure that data cannot be recalled after being erased
- Capture time-stamped IHD screen shots before and after erasing the memory.

Glossary

Term	Definition
Active mode	IHD is switched on and undertaking its primary function, e.g. IHD display is activated
Advanced Metering Installation (AMI) meter	A remotely read interval meter that records interval energy data and complies with the Minimum Functionality Specification (Victoria) release 1.1
AS/NZS	Australia/New Zealand Standard
Binding	The process of joining a ZigBee certified IHD to a smart meter so that the IHD can determine energy consumption data from the smart meter
Distribution network service provider (DNSP)	DNSPs operate the Victorian electricity grid infrastructure that distributes generated electricity to customer premises
Encryption	The mechanism used to securely encode data passed between the IHD and the sensing apparatus
Electrical energy consumption	The use of electrical energy, measured in kWh
Firmware	The combination of a hardware device, computer instructions and data that reside as read-only software on a device
Mains powered	Powered by general-purpose (mains) alternating current (AC) electric power supply
Meter	A device complying with Australian Standards which measures and records the production and consumption of electrical energy
NATA	National Association of Testing Authorities
Power	The rate at which electrical energy is consumed, measured in Watts
Sensing apparatus	The apparatus from which an IHD is capable of obtaining electrical consumption information, including an AMI meter or power coil
Sleep mode	IHD is switched on but not undertaking its primary function and is readily switched back to active mode (e.g. IHD screen is deactivated)
Smart meter	See AMI meter definition
Tariff	Rate charged for electricity consumption in cost per unit of energy consumed
ZigBee	A specification for high level communication protocols, which enables wireless data transfer over a short range

Appendix A: Laboratory test report template

Victorian Energy Upgrades (VEU) program: In-home display (IHD) unit

Laboratory test report: cover sheet

IHD unit type: ZigBee Non-ZigBee

IHD unit details

Brand

Model

Firmware version

Serial number(s)

Date(s) of
manufacture

Power supply Battery Mains powered (voltage: ____V)

Laboratory details

Laboratory name

Accreditation

Testing officer

Testing dates

Applicant name

Applicant address

Summary

Has the IHD unit passed all requirements as outlined in the commission's In-Home Display (IHD) Unit Product Application Guide?

Yes No Not applicable

Signature:

Date:

Laboratory test report checklist

Please complete the following checklist of the laboratory test documentation to be provided to the commission and attach it to the laboratory test report.

Data to be provided to the commission	Data supplied? (Y/N)
Laboratory test report cover sheet	
Testing details	
Relevant test report summary	
IHD screen shots	
Time series data sets and data plots	
IHD technical specifications	
Electrical authority approval or equivalent (where relevant)	
MEPS registration (IHD units with applicable external power supplies only)	
Manufacturer's battery lifetime statement (solely battery powered IHD unit components only)	
C-tick or RCM compliance label for EMC	
ZigBee smart energy profile specification version 1.1 certification, backwards compatible with certified ZigBee smart energy products version 1.0 (ZigBee IHD units only)	
IHD data encryption specifications (non-ZigBee IHD units only)	
Manufacturer's declaration of IHD data encryption (non-ZigBee IHD units only)	

Testing details

Testing equipment

Please provide the details of all testing equipment used during the laboratory test.

Testing equipment				
Equipment type (e.g. power meter)	Brand	Model	Serial no.	Calibration date

Test configuration diagram

Please provide a diagram outlining the configuration of testing equipment and the IHD unit used during the laboratory test. Example test configurations are provided in the commission laboratory test for ZigBee and non-ZigBee IHD units in **Error! Reference source not found.** and **Error! Reference source not found.**

Test configuration diagram

Tariff information

Please provide details of the tariff rates programmed into the IHD unit for testing in cost per unit of energy consumed (e.g. \$0.21/kWh, 3pm-9pm weekdays), list the methods by which tariff rates can be entered into the IHD unit (e.g. manual programming, download from the meter) and list the number of tariffs the IHD unit is capable of supporting.

Tariff information
Cost per kWh
Tariff input methods
Tariffs supported by the IHD

ZigBee certified IHD unit test report summary

Report on whether the following test conditions were met for the IHD unit tested. Space for comments is provided. Where relevant, attach IHD unit screen shots (or photographs), data sets and time series plots associated with each test as outlined in Appendix B and C. For further details on test conditions, please refer to Section 3 of this guide.

Review of specifications:

No.	Review name	Criteria	Pass / fail	Comments
1	ZigBee certification	IHD unit has been tested and certified by the ZigBee alliance as compliant with ZigBee smart energy profile Specification version 1.1 and is backwards compatible with certified ZigBee smart energy products version 1.0		
2	Battery lifetime	If any IHD unit component is solely battery powered, the IHD battery / batteries have a manufacturer's rated lifetime of at least 5 years when operating under normal circumstances		

Test results summary:

No.	Test name	Criteria	Pass / fail	Comments
1	Tariff display	IHD unit displays the electricity tariff in cost per unit of energy consumed relevant to the time period displayed		
2	Polling frequency	IHD unit determines electrical consumption information from the smart meter at least every 30 seconds		
3	Power consumption display	IHD unit displays average total electrical power consumption (in watts or kW), accurate to the smart meter, in a numerical and non-numerical format, updated at least every 30 seconds		
4	Energy consumption and cost display	IHD unit displays total energy consumption (in kWh) and the cost of that consumption accurate to the smart meter, in a numerical and non-numerical format, updated at least every 30 seconds		
5	Historical data storage and display	IHD unit stores and displays 45 days electrical energy consumption and cost information in a numerical and non-numerical format, in intervals no longer than one hour per day and one day per week		
6	IHD power consumption	If mains powered, the IHD unit uses no more than 0.6W of power on average.		
7	Erasable memory	Consumption, tariff and other data entered into the IHD unit can be permanently erased from the IHD unit's memory by the consumer		
N/A		For all tests performed, the IHD unit did not exhibit unexpected or perverse behaviours.		
N/A		At all times, the IHD unit was observed to conform to the minimum eligibility criteria outlined in the VEET Regulations.		

Were there any deviations from the test method, and/or suggestions for improvement of the test methodology?

4.1 Non-ZigBee IHD unit test report summary

Report on whether the following test conditions were met for the IHD unit tested. Space for comments is provided. Where relevant, attach IHD unit screen shots (or photographs), data sets and time series plots associated with each test as outlined in Appendix B and C. For further details on test conditions, please refer to Section 4 of this guide.

4.2 Review of specifications:

No.	Review name	Condition	Pass / fail	Comments
1	Data encryption	The communication protocol between the IHD unit and the sensing apparatus is securely encrypted		
2	Battery lifetime	If any IHD unit component is solely battery powered, the IHD battery / batteries have a manufacturer's rated lifetime of at least 5 years when operating under normal circumstances		

Test results summary:

No.	Test name	Condition	Pass / Fail	Comments
1	Tariff display	IHD unit displays the electricity tariff in cost per unit of energy consumed relevant to the time period displayed		
2	Polling frequency	IHD unit determines electrical consumption information from the sensing apparatus at least every 30 seconds		
3	Power consumption display	IHD unit displays average total electrical power consumption (in watts or kW), accurate to within 5% of actual power consumption, in a numerical and non-numerical format, updated at least every 30 seconds		
4	Energy consumption and cost display	IHD unit displays total energy consumption (in kWh) and the cost of that consumption, accurate to within 5% of actual energy consumption, in a numerical and non-numerical format, updated at least every 30 seconds		
5	Historical data storage and display	IHD unit stores and displays 45 days electrical energy consumption and cost information in a numerical and non-numerical format, in intervals no longer than one hour per day and one day per week		

No.	Test name	Condition	Pass / Fail	Comments
6	IHD power consumption	If mains powered, the IHD unit uses no more than 0.6W of power on average		
7	Erasable memory	Consumption, tariff and other data entered into the IHD unit can be permanently erased from the IHD unit's memory by the consumer		
N/A		For all tests performed, the IHD unit did not exhibit unexpected or perverse behaviours		
N/A		At all times, the IHD unit was observed to conform to the minimum eligibility criteria outlined in the VEET Regulations.		

Were there any deviations from the test method, and/or suggestions for improvement of the test methodology?

Appendix B: Laboratory test results – IHD screen shots

For each laboratory test undertaken for ZigBee or non-ZigBee IHD units attach relevant, clearly labelled screen shots (or photographs if this is not possible) of the IHD unit display as outlined in the table below.

IHD unit screen shots (ZigBee and non-ZigBee IHD units)		
Test no.	Test name	IHD display screen shots
1	Tariff display	<ul style="list-style-type: none"> Tariff displayed
3	Power consumption display	<ul style="list-style-type: none"> Average electrical power consumption (W) displayed in a numerical format Average electrical power consumption (W) displayed in a non-numerical format
4	Energy consumption and cost display	<ul style="list-style-type: none"> Total energy consumption (in kWh) displayed in a numerical format Total energy consumption (in kWh) displayed in a non-numerical format Total energy consumption cost displayed in a numerical format Total energy consumption cost displayed in a non-numerical format
5	Historical data storage and display	<ul style="list-style-type: none"> 45 days energy consumption data displayed in a numerical format* 45 days energy consumption data displayed in a non-numerical format* 45 days energy consumption cost data displayed in a numerical format* 45 days energy consumption cost data displayed in a non-numerical format* Example of energy consumption displayed in a numeric format in intervals no longer than one hour per day Example of energy consumption displayed in a numeric format in intervals no longer than one day per week Example of energy consumption displayed in a non-

		<p>numeric format in intervals no longer than one hour per day</p> <ul style="list-style-type: none"> • Example of energy consumption displayed in a non-numeric format in intervals no longer than one day per week • Example of energy consumption cost displayed in a numeric format in intervals no longer than one hour per day • Example of energy consumption cost displayed in a numeric format in intervals no longer than one day per week • Example of energy consumption cost displayed in a non-numeric format in intervals no longer than one hour per day • Example of energy consumption cost displayed in a non-numeric format in intervals no longer than one day per week • * data does not have to be displayed all in one screen
7	Erasable memory	<ul style="list-style-type: none"> • Time-stamped screen shot before erasing memory • Time-stamped screen shot after erasing memory

Appendix C: Laboratory test results – Data sets and plots

For each laboratory test undertaken, attach relevant time series data sets and data plots for ZigBee Certified and non-ZigBee IHD units as outlined in the tables below.

All data sets should be supplied in Microsoft Excel format with clearly labelled column headings stating the parameter recorded and the measurement units.

Data sets and plots (ZigBee IHD units)				
Test no.	Test name	Data sets & plots	Data logging points	Notes
2	Polling frequency	IHD polling frequency v time (30 minutes)	ZigBee packet sniffer	
3	Power consumption display	Power (W) v time (4 hours)	Smart meter IHD unit	Record actual power load used every 15 minutes
4	Energy consumption and cost display	Energy (kWh) v time (4 hours)	Smart meter IHD unit	Record actual power load used every 15 minutes
		Energy consumption cost v time (4 hours)	Smart meter (in conjunction with tariff information) IHD unit	
6	IHD unit power consumption	IHD energy consumption v time (24 hours)	Power meter	

Data sets and plots (non-ZigBee IHD units)

Test no.	Test name	Data sets & plots	Data logging points	Notes
2	Polling frequency	IHD polling frequency v time (30 minutes)	IHD unit	
3	Power consumption display	Power (W) v time (4 hours)	Electricity meter IHD unit	Record actual current used every hour
4	Energy consumption and cost display	Energy (kWh) v time (4 hours)	Electricity meter IHD unit	Record actual current used every hour
		Energy consumption cost v time (4 hours)	Electricity meter (in conjunction with tariff information) IHD unit	Record tariff programmed into IHD and actual current used every hour
6	IHD power consumption	IHD energy consumption v time (24 hours)	Power meter	

Document version control

The RM reference for this document is: C/18/29531

Version	Amendments made	Date published
1.0	First release under the 2018 VEET Regulations	10 December 2018